

ROUNDTEST RA-2100 SERIES

Bulletin No. 1901



**Best in class roundness/cylindricity measuring system
for the ultimate in accuracy and ease-of-use**

Mitutoyo

ROUNDTEST/ROUNDTEST EXTREME — Best in class roundness/cylindricity measuring system for the ultimate in accuracy and ease-of-use

The RA-2100 series is available in two types: the RA-2100AS/AH/DS/DH models, and the RA-2100S/H CNC machines that feature detector orientation control (see pages 3 and 4 for details).

Each model incorporates an automatic turntable for simple, accurate workpiece centering and leveling providing significant time savings in performing roundness/cylindricity measurement set up.



Mitutoyo

Many optional accessories, such as styli, chucks and calibration standards, are available to make it easy to measure a wide variety of workpieces (see pages 10 and 11 for details).

ROUNDPAK data analysis software allows a wide range of analyses to be performed easily (see pages 8 and 9 for details).



Detector orientation control in 1° increments (unique to RA-2100CNC)

Surface roughness measurement (Optional)

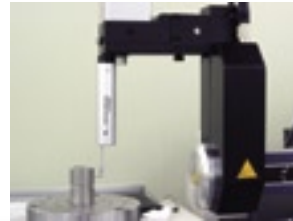

RA-2100CNC



RA-2100AS/AH/DS/DH



RA-2100H CNC

ROUNDTTEST EXTREME RA-2100S/H CNC — CNC Roundness/Cylindricity Measuring Systems... For Greatly Enhanced Productivity and Efficiency

Turntable features high accuracy and ease-of-use

High turntable rotational accuracy, in both the radial (0.02 + 3.8H/10000 μ m) and axial (0.02 + 3.8X/10000 μ m) directions, allows high accuracy flatness testing to be performed in addition to roundness and cylindricity measurements. The automatic alignment feature of the turntable enhances productivity by eliminating time-consuming workpiece centering and leveling operations.

Detector orientation control in 1° increments supports CNC automatic measurement

Detector holder arm orientation (vertical/horizontal) and detector rotation (within a range between 0 to 270°, in increments of 1°) are automatically controlled to provide automatic and continuous measurement of OD, ID, and top and bottom surfaces. Also, the powerful off-line teaching function allows a part program to be created with ease.

Mitutoyo linear scales ensure high accuracy CNC measurements

Mitutoyo linear scales are used in the X/Z drive unit to guarantee high precision positioning vital for automatic CNC operation.

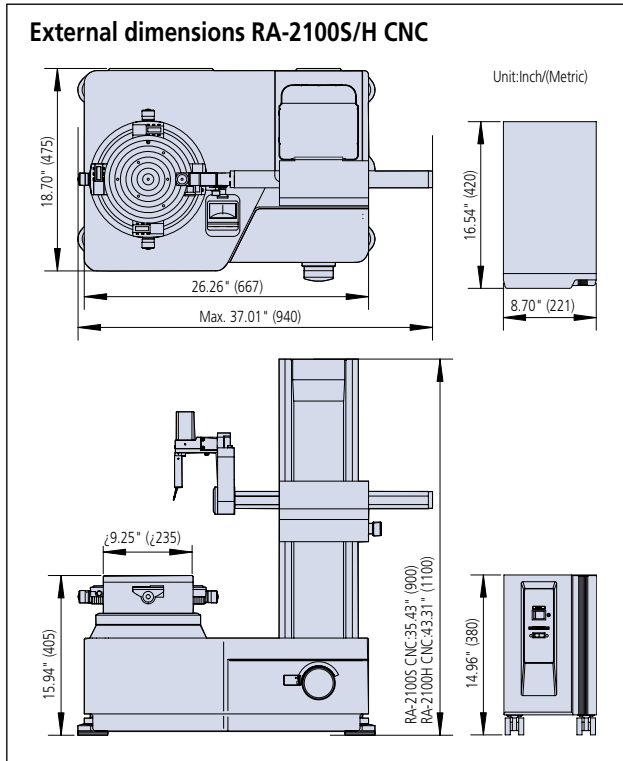

Detector rotation mechanism (0 to 270°, increments of 1°)



Holder-arm orientation switching (vertical position - horizontal position)

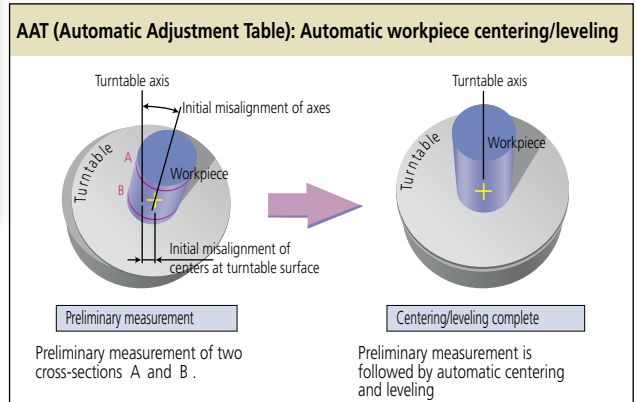

Standard accessories (RA-2100S/H CNC)

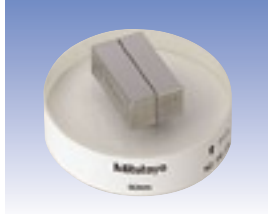

Magnification calibration kit
No.997090
 A combination of gage blocks and an optical flat.

Thin workpiece stage
No.12AAE404

Origin point gage for CNC
No.12AAD877

Reference hemisphere
No.211-016

* See page 10 and 11 for optional accessories including interchangeable styli

Surface roughness measurement function

(Roughness measurement unit: optional)

This is a multi-sensor compatible system that is capable of accepting not only the roundness measuring system standard probe but also a surface roughness measuring detector. It permits verification of both geometric tolerancing on roundness or cylindricity and surface roughness to be performed with a single system.

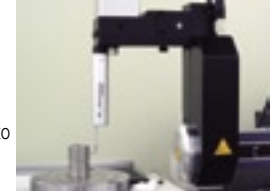

Measuring direction

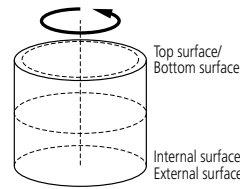

Roughness in circumferential direction

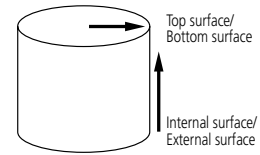

Roughness in horizontal and vertical directions

Specification

Item	Model No.	RA-2100S CNC		RA-2100H CNC		
		Order No.	211-847-1 * Inch/(Metric)	211-848-1* Inch/(Metric)		
Turntable	Rotational accuracy	Radial direction	0.8+0.38H μinch ((0.02 + 3.8H/10000)μm); H = probing height above turntable			
		Axial direction	0.8+0.38X μinch ((0.02 + 3.8X/10000)μm); X = distance from the turntable axis			
	Rotational speed	2, 4, 6, 10rpm				
	Effective table diameter	9.25" (235mm)				
	Centering/leveling adjustment	Automatic				
	Centering range	±0.11" (±3mm)				
	Leveling range	±1°				
	Maximum table loading	30kgf				
	Maximum measuring diameter	10.07" (256mm)				
Maximum workpiece diameter	22.83" (580mm)					
Vertical drive unit (Z-axis column unit)	Traverse straightness	4.7μinch/3.93" (0.12μm/100mm) (λc2.5)		4.7μinch/3.93" (0.12μm/100mm) (λc2.5)		
		7.1μinch/11.81" (0.18μm/300mm) (λc2.5)		11.8μinch/19.68" (0.3μm/500mm) (λc2.5)		
	Parallelism with turntable axis	28μinch/11.81" (0.7μm/300mm) (generatrix basis)		47μinch/19.68" (1.2μm/500mm) (generatrix base)		
	Traverse speed	1.37"/s (35mm/s) maximum for positioning; 0.02, 0.04, 0.08, 0.20"/s (0.5, 1, 2, 5mm/s) for measuring				
	Maximum probing height	for measuring OD	11.81" (300mm)	19.68" (500mm)		
	for measuring ID	11.81" (300mm)	19.68" (500mm)			
Radial drive unit	Maximum probing depth	1.02" (26mm) for ø0.50" (ø12.7mm) or more				
		4.09" (104mm) for ø1.27" (ø32mm) or more (using the standard stylus)				
	Arm straightness	28μinch/5.90" (0.7μm/150mm) (λc2.5)				
	Perpendicularity to turntable axis	40μinch/5.90" (1.0μm/150mm) (generatrix basis)				
	Traverse range	6.88" (175mm) (±25mm from the turntable center)				
Detector	Traverse speed	0.78"/s (20 mm/s) maximum for positioning; (0.02, 0.04, 0.20"/s (0.5, 1, 5mm/s) for measuring				
	Measuring force	7-40mN				
	Stylus tip shape/material	ø0.06" (ø1.6mm) tungsten carbide ball				
	Range	Detecting range	±0.015" (±400μm)			
		Tracking range	±0.19" (±5mm)			
Other	Rotation (within the range 0 to 270°, in increments of 1°)					
Others	Line voltage	100-240V				
	Air pressure	0.39MPa				
	Air consumption	30 L/min in standard condition (Air supply of 80 L/min or more)				
	Mass of the main unit	396lb (180kg)		440lb (200kg)		

*To specify the power line connector required add the following suffixes (e.g.211-847-1A):
 A for UL/CSA type, C for JIS type, D for CEE type, E for BS type, DC for CCC type K for EK type.

ROUNDTEST RA-2100AS/AH/DS/DH — Roundness/Cylindricity Measuring System... A Fusion of the Highest Level of Accuracy and Ease-of-Use

Highly accurate and easy-to-use turntable

With extremely high rotational accuracy, both in the radial and axial directions, the turntable allows high accuracy flatness testing to be performed in addition to roundness and cylindricity measurements. Incorporating an automatic centering/leveling turntable, the top-of-the-line RA-2100AS/AH models relieve the operator of the bothersome task of workpiece centering and leveling. A guidance system is incorporated into the turntables on the RA-2100DS/DH models to help the operator perform manual centering and leveling smoothly and simply.

Continuous measurement improves productivity

Measurement/analysis of outside and inside diameters*1 on a hybrid workpiece (as in concentricity measurement) can be performed continuously without the need to change the traverse direction of the detector.

*1: Inside diameter up to 50 mm.

Highly repeatable measurements with high-accuracy scales

Mitutoyo linear scales are used in the X/Z drive unit to guarantee the high precision positioning so vital for repetitive measurement.

Readily upgraded to CNC operation

The system can be upgraded to CNC operation by replacing and adjusting the detector unit. (This task should be performed by a Mitutoyo technician.)



Surface roughness measurement function (Surface roughness unit: option)

A surface roughness detector, compliant with the relevant International Standards, can be mounted in place of the roundness measuring detector. This creates a multiple sensor system that can not only test the geometrical roundness/cylindricity of a surface but also the roughness of that surface as well.

* Please contact Mitutoyo for further information.

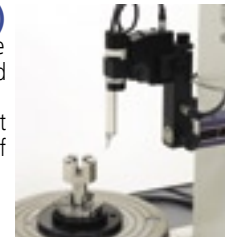

External dimensions RA-2100AS/AH/DS/DH

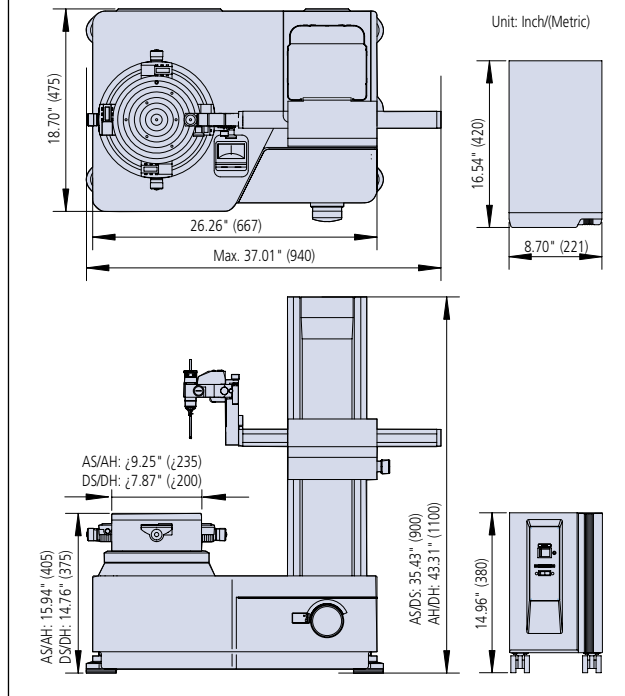

AAT (Automatic Adjustment Table): Automatic workpiece centering/leveling

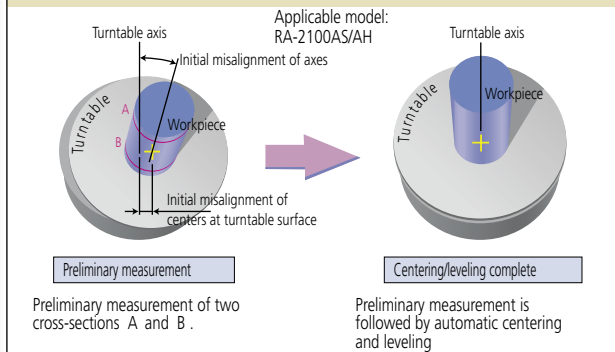

DAT (Digital Adjustment Table):

Workpiece centering/leveling with Digimatic micrometer heads

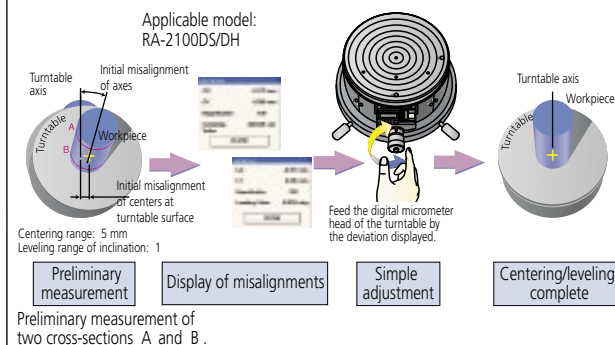

Accessories

Standard



Magnification calibration kit

No. 997090
A combination of gage blocks and an optical flat.

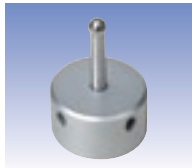

Origin-point gage

No. 998382
A gage for zero setting of the R-axis and Z-axis.

Reference hemisphere

No. 211-016

Optional

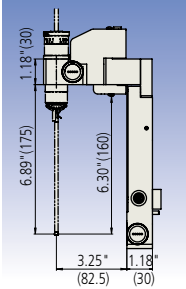

Double length holder

No. 12AAF203
For extra-deep holes.

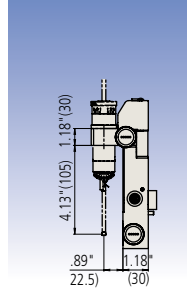

Large diameter holder

No. 12AAF204
For measuring a larger OD
2.76" to 16.54"
(70 to 420 mm).



Thin workpiece stage

No. 356038
Loading diameter:
3.94" (100 mm)
Dimensions (D x H):
4.13" x .98" (105 x 25 mm)
Mass: 3.75 lbs. (1.7kg)

* See page 10 for optional accessories common to the RA-2100 series. See page 11 for interchangeable styli for use with the RA-2100AS/AH/DS/DH.

Specification

Inch/(Metric)

Item	Model No. Order No.	RA-2100AS	RA-2100DS	RA-2100AH	RA-2100DH
		211-843 * -1 Inch/(Metric)	211-863 * -1 (Metric) 211-873 * -1 inch	211-844 * -1 Inch/(Metric)	211-864 * -1 (Metric) 211-874 * -1 inch
Turntable	Rotational accuracy	Radial direction (0.8+0.38H) μ inch ((0.02 + 3.8H/10000) μ m); H = probing height above turntable Axial direction (0.8+0.38X) μ inch ((0.02 + 3.8X/10000) μ m); X = distance from the turntable axis			
	Rotational speed	2, 4, 6, 10rpm			
	Effective table diameter	9.25" (235mm)	7.87" (200mm)	9.25" (235mm)	7.87" (200mm)
	Centering/leveling adjustment	AAT	DAT	AAT	DAT
	Centering range	$\pm 0.11"$ (± 3 mm)	$\pm 0.19"$ (± 5 mm)	$\pm 0.11"$ (± 3 mm)	$\pm 0.19"$ (± 5 mm)
	Leveling range	$\pm 1^\circ$			
	Maximum table loading	30kg			
	Maximum measuring diameter	11.81" (300mm)			
Vertical drive unit (Z-axis column unit)	Maximum workpiece diameter	22.83" (580mm)			
	Traverse straightness ($\lambda c 2.5$)	4.7 μ inch/3.93" (0.12 μ m/100mm) 7.1 μ inch/11.81" (0.18 μ m/300mm)		4.7 μ inch/3.93" (0.12 μ m/100mm) 11.8 μ inch/19.68" (0.3 μ m/500mm)	
	Parallelism with turntable axis	28 μ inch/11.81" (0.7 μ m/300mm) generatrix basis		47 μ inch/19.68" (1.2 μ m/500mm) generatrix base	
	Traverse speed	1.37"/s (35mm/s) maximum for positioning; 0.02, 0.04, 0.08, 0.20"/s (0.5, 1, 2, 5mm/s) for measuring			
	Maximum probing height	for measuring OD 11.81" (300mm) for measuring ID 11.81" (300mm)		19.68" (500mm) 19.68" (500mm)	
Radial drive unit	Maximum probing depth	3.93" (100mm) (using the standard stylus)			
	Arm straightness	28 μ inch/5.90" (0.7 μ m/150mm) ($\lambda c 2.5$)			
	Perpendicularity to turntable axis	40 μ inch/5.90" (1.0 μ m/150mm) (generatrix basis)			
	Traverse range	6.88" (175mm) (± 25 mm from the turntable center)			
Detector	Traverse speed	0.78"/s (20 mm/s) maximum for positioning; (0.02, 0.04, 0.20"/s (0.5, 1, 5mm/s) for measuring			
	Measuring force	7–10mN (changeable in 5 steps)			
	Stylus tip shape/material	$\varnothing 0.06"$ ($\varnothing 1.6$ mm) tungsten carbide ball			
	Range	Detecting range $\pm 0.015"$ ($\pm 400\mu$ m) Tracking range $\pm 0.19"$ (± 5 mm)			
Others	Other	IN/OUT switching mechanism, measuring force changeable (in 5 steps)			
	Line voltage	100–240V			
	Air pressure	0.39MPa			
	Air consumption	30 L/min in standard condition (air supply of 80 L/min or more)			
Basic unit mass	396lb (180kg)		440lb (200kg)		

*To specify the power line connector required add the following suffixes (e.g.211-843-1A):
A for UL/CSA type, C for JIS type, D for CEE type, E for BS type, DC for CCC type K for EK type.

Roundness/cylindricity measurement/analysis software

ROUNDPAK®

Software for easy control of preliminary setup, measurement, analysis, and result output

Preliminary setup

Centering/leveling the workpiece

Mitutoyo's unique AAT functionality (which measures initial misalignment and automatically centers and levels the workpiece) and DAT functionality (which measures and displays the amount of adjustment needed to center and level the workpiece) have been commended by customers as superb solutions for preliminary centering/leveling setup.

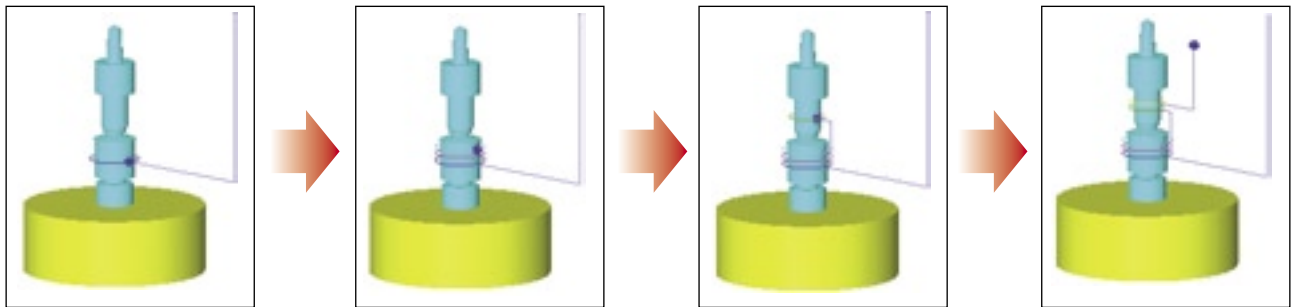

Simulating part programs

The part program (automatic measurement procedure) can be simulated in 3D form on screen displays generated by the design data generation function.

3D simulation screens (work-view windows) can be generated after entering CAD data (in IGES, DXF form) and text data.

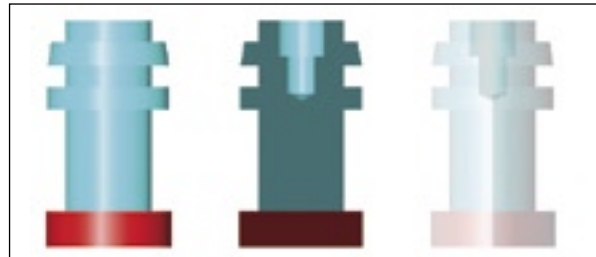

Measurement

Measurement mode

Two modes are available for selective use: 'Simple mode' to simply measure and 'Part program mode' for measurement and analysis of multiple items.

Convenient measuring functions

(1) Edge detection function

A coordinate system can be set up for a workpiece. This allows measurements to be repeated easily on identical workpieces.

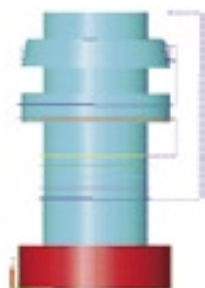

(2) Continuous OD/ID measuring function

Both the OD and ID of a workpiece can be measured in succession without the need for changing the traverse direction of the stylus.

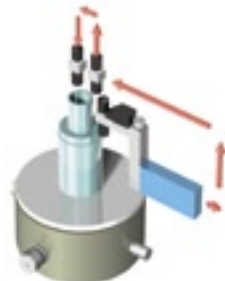

(3) Partial arc measuring function

This enables measurements to be performed on a workpiece having a projected section or incomplete circumference.

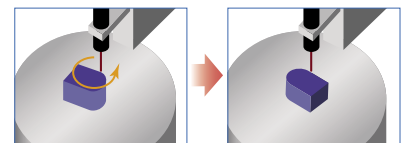

Mitutoyo

Analysis, results output

A variety of parameters and analysis functions

A variety of parameters, not only for roundness and cylindricity, but also for flatness and parallelism, can be handled. Also included are functions for design data best-fit analysis, harmonic analysis and circumferential peak-bottom detection, etc.

*1: For further information about parameters, refer to the ROUNDPAK catalog.

Result output

Result output is possible in the customer's original format according to the layout prescribed for the location, size, etc., of the analysis results including graphics and drawings. The original layout, if saved, allows automatic operation from measurement to calculation (automatic saving, results display, and printing) just by pressing the measurement start button.

Measurement data utilization

(1) Re-calculation function

It is possible to re-calculate an analysis using measurement data previously obtained but using changed measurement conditions (filter-cutoff values, etc.), or different analysis parameters.

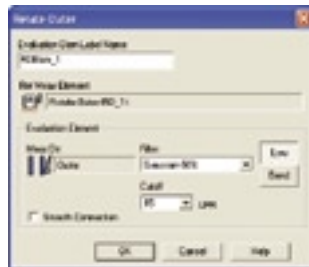

(2) Data deletion function

This function allows calculation/analysis to be performed with only the remaining data after deleting unnecessary point data (from a notched section, or from an area outside the target area on the workpiece) from that obtained by measurement.

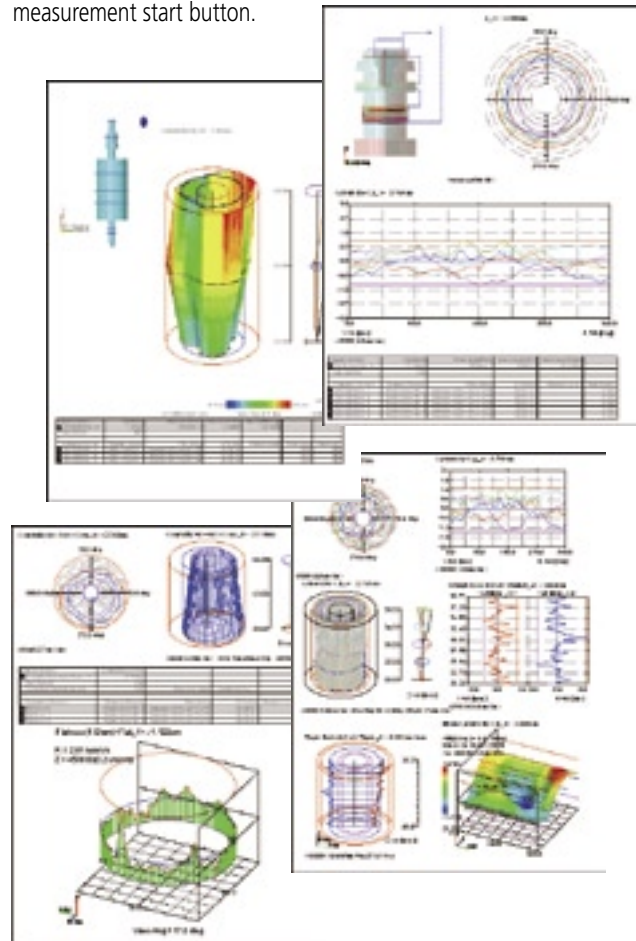
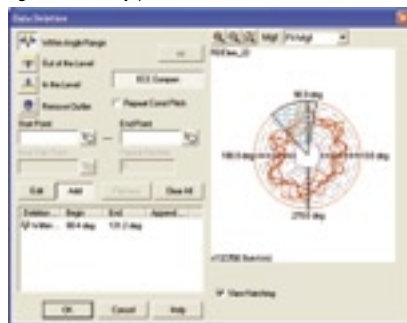

Graphical display of results

Results of analyses, such as for cylindricity or coaxiality, can be visually represented by a 3D graphical display. This 3D graphic can be pasted into a report.

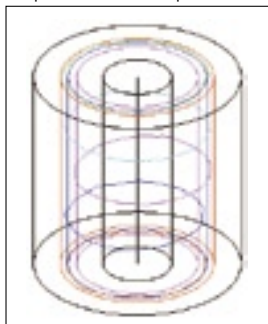

Normal display

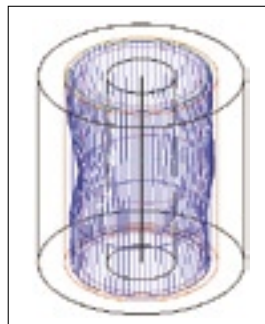

Wire-frame display

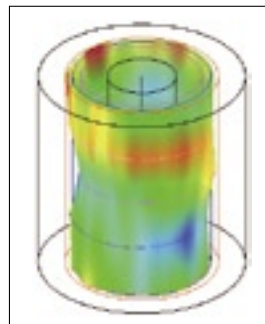

Surface map display

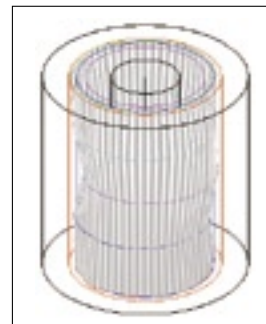

Shading display

OPTIONAL ACCESSORIES

Interchangeable Styli for RA-2100S/H CNC

Application/Type	Groove	Flat surface	General purpose	Notch
Order No.	12AAE310	12AAE302	12AAF150	12AAE309
Stylus tip	ø.06" (ø1.6 mm) tungsten carbide	ø.06" (ø1.6 mm) tungsten carbide	ø.06" (ø1.6 mm) tungsten carbide	ø.06" (ø1.6 mm) tungsten carbide
Dimensions inch (mm)				
Application/Type	ø.06" (ø1.6 mm) ball	ø.03" (ø0.8 mm) ball	ø.02" (ø0.5 mm) ball	Deep groove
Order No.	12AAE303	12AAE304	12AAE305	12AAE308
Stylus tip	ø.06" (ø1.6 mm) tungsten carbide	ø.03" (ø0.8 mm) tungsten carbide	ø.02" (ø0.5 mm) tungsten carbide	ø.06" (ø1.6 mm) tungsten carbide
Dimensions inch (mm)				
Application/Type	Deep hole A		Deep hole B	
Order No.	12AAE306		12AAE307	
Stylus tip	ø.06" (ø1.6 mm) tungsten carbide		ø.06" (ø1.6 mm) tungsten carbide	
Dimensions inch (mm)				

Options common to the RA-2100S/H CNC, RA-2100AS/AH/DS/DH

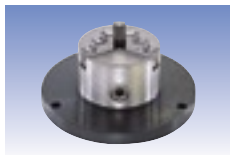

Centering chuck

(key operated)

No.211-014

Suitable for holding longer parts and those requiring a relatively powerful clamp.

- Holding capacity: Internal jaws, OD: .04"-1.38" (1-35 mm) Internal jaws, ID: 1.30"-3.35" (33-85 mm) External jaws, OD: 1.18"-3.15" (30-80 mm)
- External dimensions: ø.618"x2.99" (ø157x76 mm)
- Mass: 8.38 lbs. (3.8 kg)



Centering chuck

(ring operated)

No.211-032

Suitable for holding small parts with easy-to-operate knurled-ring clamping.

- Holding capacity: Internal jaws, OD: .04"-1.42" (1-36 mm) Internal jaws, ID: .55"-2.76" (14-70 mm) External jaws, OD: .04"-2.95" (1-75 mm)
- External dimensions: ø.465"x1.34" (ø118x34 mm)
- Mass: 2.65 lbs. (1.2 kg)



Micro-chuck

No.211-031

Used for clamping a workpiece with a diameter less than .04" (1 mm) that the centering chuck cannot handle.

- Holding capacity: up to ø.06" (ø1.5 mm)
- External dimensions: ø.465"x1.91" (ø118x48.5 mm)
- Mass: 1.77 lbs. (0.8 kg)

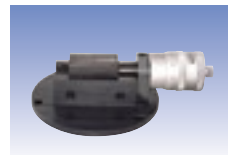

Magnification calibration gage

No.211-045

Used for normalizing detector magnification by calibrating detector travel against displacement of a micrometer spindle.

- Maximum calibration range: 400µm
- Graduation: 0.2µm
- External dimensions (WxDxH): 9.25" (max)x7.28"x2.76" (235(max)x185x70 mm)
- Mass: 8.82 lbs. (4kg)

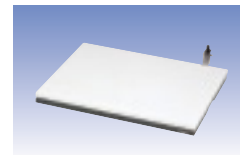

Vibration isolator

No.178-025

- Vibration isolation method: Air suspended, diaphragm isolation system.
- External dimensions: ø2.76"x9.84" (ø70x250 mm)

Vibration isolator stand

No.178-024

Cylindrical square

- Straightness: 0.5µm
- Cylindricity: 2µm
- External dimensions: ø2.76"x9.84" (ø70x250 mm)
- Mass: 16.53 lbs. (7.5kg)

Protective shield

No.12AAB949

Interchangeable Styli for RA-2100AS/AH/DS/DH

Inch (Metric)

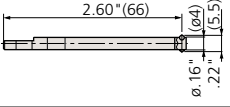
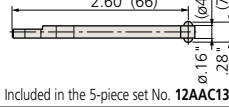
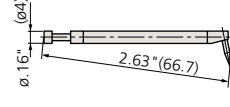
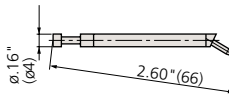
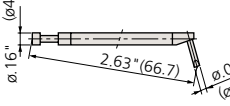
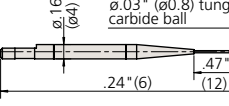
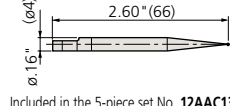
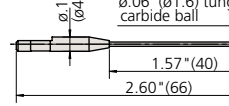
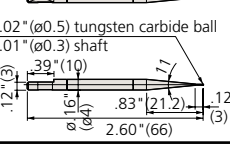
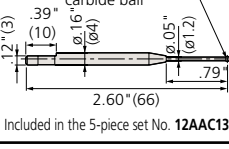
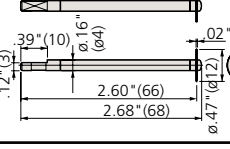
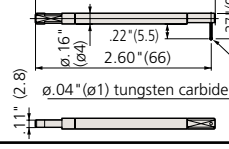
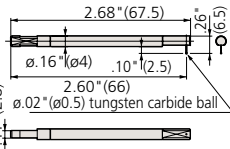
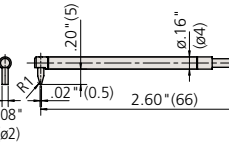
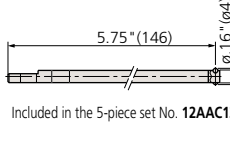
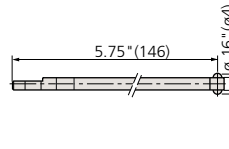
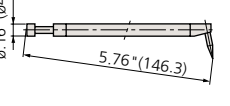
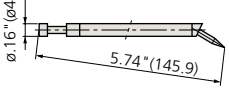
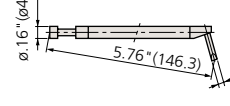
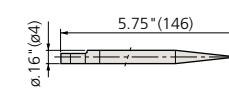
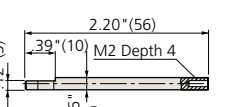
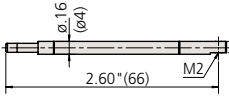
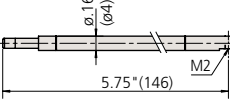
Application/Type	Standard type (supplied)	Notch	Deep groove	Corner
Order No.	12AAB681	12AAB682	12AAB683	12AAB684
Stylus tip	ø.06" (ø1.6) tungsten carbide	ø.12" (ø3) tungsten carbide	ø.01" (0.25) radius sapphire	ø.01" (0.25) radius sapphire
Dimensions inch (mm)				
		Included in the 5-piece set No. 12AAC134	Included in the 5-piece set No. 12AAC134	
Application/Type	Cutter mark	Small hole ø.03" (ø0.8)	Small hole	Small hole ø.06" (ø1.6)
Order No.	12AAB685	12AAE859	12AAB686	12AAE855
Stylus tip	.59" (15) radius tungsten carbide	ø.03" (ø0.8) tungsten carbide	ø.04" (ø1) tungsten carbide	ø.06" (ø1.6) tungsten carbide
Dimensions inch (mm)				
			Included in the 5-piece set No. 12AAC134	
Application/Type	Extra small hole Depth: .12" (3)	ø.06" (ø1.6) ball	Disk	Crank tip: ø.02" (ø0.5)
Order No.	12AAB687	12AAB674	12AAB694	12AAB696
Stylus tip	ø.02" (ø0.5) tungsten carbide	ø.06" (ø1.6) tungsten carbide	ø.47" (ø12)	ø.06" (ø1.6) tungsten carbide Depth: .10" (2.5)
Dimensions inch (mm)				
		Included in the 5-piece set No. 12AAC134		
Application/Type	Crank (tip: ø1 mm)	Flat surface	2X-long type*	2X-long type notch*
Order No.	12AAB695	12AAE856	12AAB688	12AAB689
Stylus tip	.04" (ø1) tungsten carbide Depth: .22" (5.5)	Tungsten carbide	ø.06" (ø1.6) tungsten carbide	ø.12" (ø3) tungsten carbide
Dimensions inch (mm)				
			Included in the 5-piece set No. 12AAC134	
Application/Type	2X-long type deep groove*	2X-long type corner*	2X-long type cutter mark*	2X-long type small hole*
Order No.	12AAB690	12AAE691	12AAB692	12AAB693
Stylus tip	.01" (0.25) radius sapphire	ø.04" (ø1) tungsten carbide Sapphire	.59" (15) radius tungsten carbide	ø.04" (ø1) tungsten carbide
Dimensions inch (mm)				
Application/Type	Stylus shank	Stylus shank (standard groove)	Stylus shank (2X-long groove)	
Order No.	12AAB676	12AAE857	12AAE858	
Stylus tip	For mounting CMM stylus (mounting thread M2)			
Dimensions inch (mm)				

* Measuring is only in the vertical direction.

Measuring magnification of 20000X is available using the 2X-long stylus.

A set of five optional interchangeable styli is available including the most commonly used ones.

Customized special interchangeable styli are available on request. Please contact any Mitutoyo office for more information.



Specifications are subject to change without notice.

Note: All information regarding our products (the illustrations, drawings, dimensional, performance and other technical data) contained in this pamphlet, is to be regarded as approximate average values. We reserve the right to make changes to the corresponding designs, dimensions and weights. The stated standards, similar technical regulations, descriptions and illustrations of the products were valid at the time of printing. The latest applicable version of our General Sales Policy will apply. Only quotations submitted by Mitutoyo or our approved distributors are valid.

- Coordinate Measuring Machines
- Vision Measuring Systems
- Form Measurement
- Optical Measuring
- Sensor Systems
- Testing Equipment and Seismometer
- Digital Scale and DRO Systems
- Small Tool Instruments and Data Management

Mitutoyo America Corporation

www.mitutoyo.com

M³ Solution Centers

Aurora, Illinois

(Corporate Headquarters)
(630) 978-5385

Westford, Massachusetts

(978) 692-8765

Huntersville, North Carolina

(704) 875-8332

Mason, Ohio

(513) 754-0709

Plymouth, Michigan

(734) 459-2810

City of Industry, California

(626) 961-9661

Kirkland, Washington

(408) 396-4428

Mitutoyo

Precision is our Profession